

# INGESCO® PDC LIGHTNING ROD

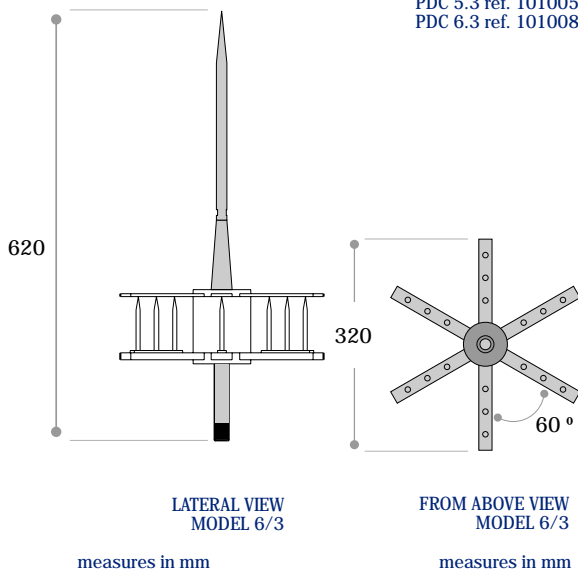

PDC 3.1 ref. 101000  
 PDC 3.3 ref. 101001  
 PDC 4.3 ref. 101003  
 PDC 5.3 ref. 101005  
 PDC 6.3 ref. 101008



## PRODUCT

Lightning rod with ESE (Early Streamer Emission) system, standardized according norm UNE 21.186.

## OPERATION

The specific function of INGESCO® PDC lightning rod is producing an upward stream of ionized particles pointed to clouds that will channel the eventual electrical discharge from its origin.

There is a different potential between the discharger (that has the same potential than the air around it) and both the air terminal tip and the deflection ensemble (they have the same potential than earth). This difference increases as atmospheric potential becomes higher because of the imminent lightning stroke.

Knowing the value of this difference  $\Delta t$  allows us to relate time and velocity of electrical discharge spread and, consequently, to calculate the lightning impact distance and the protection area that offers each lightning rod model (see table below).

The knowledge of this value allows finally to select the most appropriate lightning rod model taking into account the characteristics of the structure we want to protect and the level of protection needed according the norm UNE 21.186.

## CARACTERISTICS & BENEFITS

- 100% of efficacy in discharge capture.
- High level of protection.
- Electric continuity guaranteed. The device doesn't offer any resistance to discharge conduction.
- Lightning rod without electrical components. Maxim durability guaranteed.
- INGESCO® PDC preserves its initial properties after each discharge.
- It doesn't need external power supply.
- Operation guaranteed in any atmospheric condition (see *Norms & Tests*).

## PROTECTION AREAS

MODEL	PDC 3.1	PDC 3.3	PDC 4.3	PDC 5.3	PDC 6.3
LEVEL I	25 m	45 m	54 m	63 m	70 m
LEVEL II	43 m	65 m	74 m	84 m	92 m
LEVEL III	50 m	75 m	85 m	95 m	102 m

## TECHNICAL SPECIFICATIONS

The capture terminal of INGESCO<sup>®</sup> PDC fits the following technical specifications:

- It has a double ESE (Early Streamer Emission) system:
  - A early streamer device that produces the upward emission
  - An electro atmospheric condenser
  - An atmospheric accelerator
- An insulation system certified by the General Testing & Research Laboratory of Generalitat de Catalunya (LGAI).
- An external structure made from stainless steel AISI 316
- A deflection system made from Epoxy resin, that guaratees the device operation in any atmospheric condition.

## INSTALLATION

INGESCO<sup>®</sup> recommends its clients to follow carefully the norm UNE 21.186 for installing the INGESCO<sup>®</sup> PDC lightning rod to assure its protection efficacy.

Our Export Department (tel. +34 937 360 314, [export@ingesco.com](mailto:export@ingesco.com)) can provide you detailed information and give advice about how to install our devices.

## NORMS & TESTS

INGESCO<sup>®</sup> PDC fulfils the requirements contained in norms:

- UNE 21.186
- UNE 21.185
- NFC 17-102

Manufactured by INGESCO<sup>®</sup> from 1984, it is the first lightning rod provided with a non electronical ESE system that fulfils the requirements contained in the norm UNE 21.186.

Guaranteed by:

- Operation principle registered in patent num. 526.264 from April 16, 1984.
- Spanish Ministry of Industry register num. 150.032.

INGESCO<sup>®</sup> PDC has also been submitted to several tests and has obtained the following certifications:

- Certifications from Laboratorio Central Oficial de Electrotecnia (LCOE) and Electro-technical Laboratory LABELEC on efficacy of upward emission and norms UNE 21.186 and NFC 17-102 fulfilment.
- Intensity test certification, for overcoming the test of High Energy Wave 10/350  $\mu$ s made by Blitzchutz & EMV Technologiezentrum (BET), that guarantees conductivity after current impulses of 100 kA.
- Comparative efficacy tests by General Testing & Research Laboratory of Generalitat de Catalunya (LGAI).
- Resistance certification, when submitted to current discharges of 200 kA, according norms IEC 1312 and RP 58.01.
- Protection area certificated when installed on a pole of 6 meters length.
- Durability certification (non electric components).
- High performance in rain conditions certificate (insulation higher than 95%).
- Corrosion test certificate (for humidity condensation with sulphur dioxide), according the norm ENE-EN ISO 6988 (made by Laboratory LABELEC).
- Environmental test certification, according UNE-EN 60068-2-52: saline fog test and cyclic test (sodium chloride solution), made by Laboratory LABELEC.
- Intensity test certification (conductivity after electric current of 100 kA) for lightning protection systems components, according UNE-EN 50.164-1, made by Laboratory LABELEC.
- Extreme climate conditions test certification (temperature range: -20 °C ~ +60 °C; relative humidity range: -10% ~ + 100%)
- LABELEC product certification:
  - N / H prevention mark, according UNE-EN 50.164-1
  - Test according AENOR's RP58.01 Rules on lightning rod with ESE system